

Easel Plus

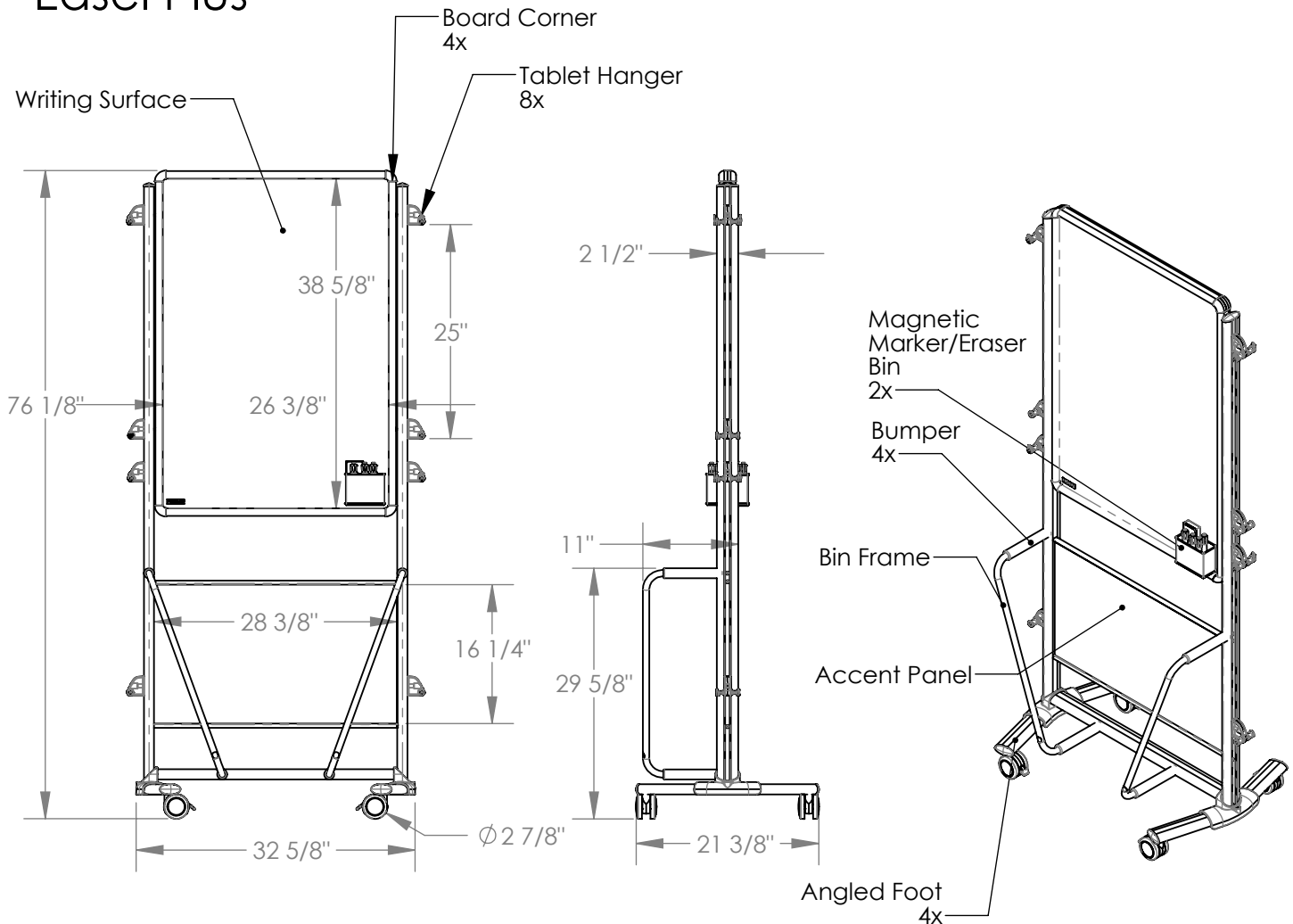

Materials:

- Framing: Satin anodized aluminum extrusion
- Foot Castings: Powder coated die cast aluminum
- Writing Surfaces: White porcelain coated 28 gauge steel sheet
- Board Corners, Rail Caps, Tablet Hangers, and Hanger Pegs: Gray thermoplastic
- Swivel Casters with Wheel Locks: Thermoplastic elastomer
- Bumpers: Black NPVC foam
- Magnetic Marker/Eraser Bins: Silver painted steel mesh weldment
- Accent Panels: Plastic

Features:

- Writing surface on front and back.
- Has angled feet for grouping with other Nexus easels and/or IdeaWalls
- Includes 2 magnetic marker/eraser bins, 1 eraser, and 4 assorted color dry erase markers.
- Designed to store and display 8 Nexus Tablets - hung from the side posts.
- Guaranteed for 10 years

Notes:

- Some assembly required
- Related Products: Nexus X-Pegs, Nexus Caddy, Nexus Tablet, Nexus Easel and Nexus IdeaWall

Partition

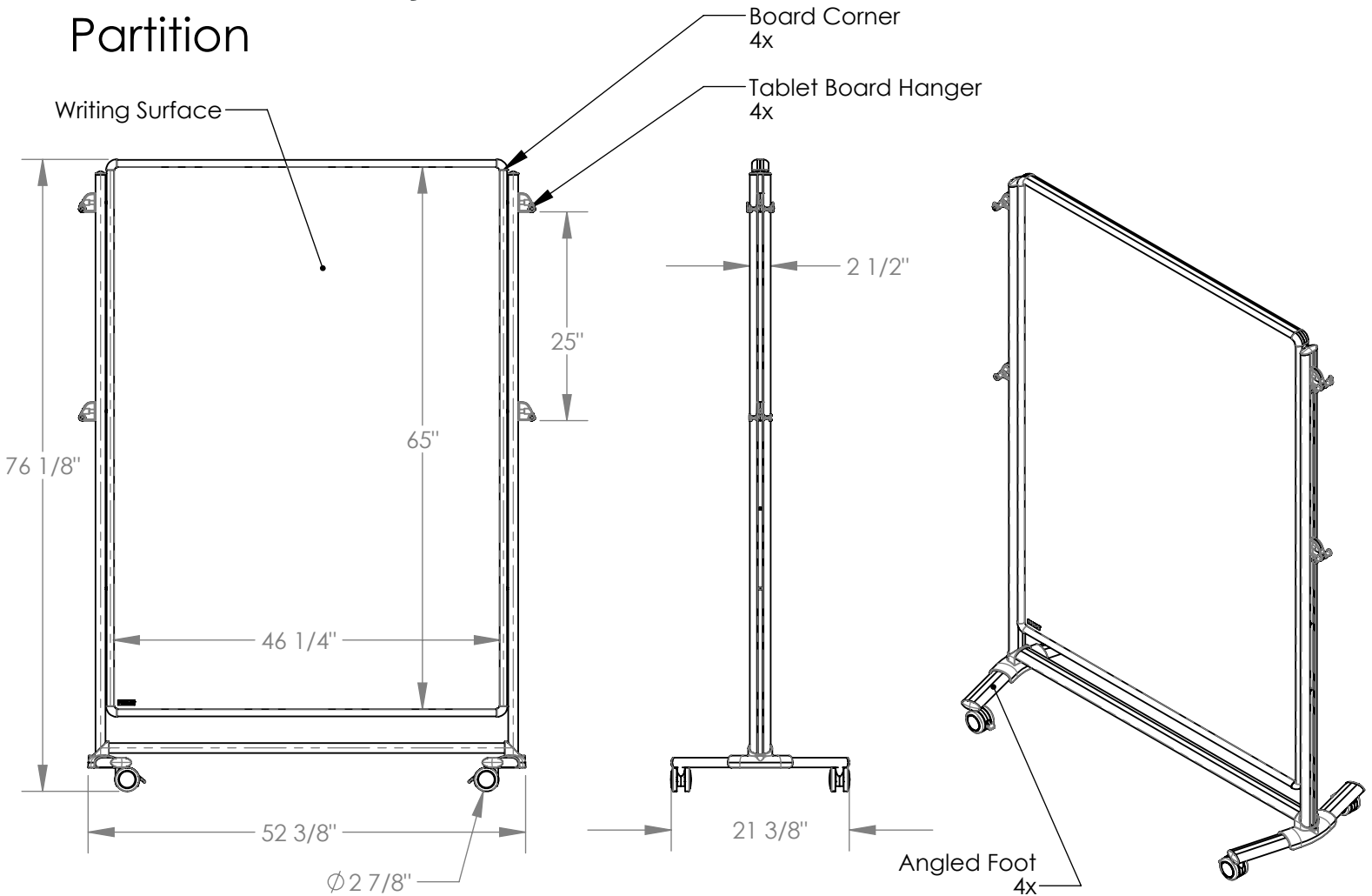

Materials:

- Framing: Satin anodized aluminum extrusion
- Foot Castings: Powder coated die cast aluminum
- Writing Surfaces: White porcelain coated 28 gauge steel sheet
- Board Corners, Rail Caps, Tablet Hangers, and Hanger Pegs: Gray thermoplastic
- Magnetic Marker/Eraser Bin: Silver painted steel mesh weldment
- Swivel Casters with Wheel Locks: Thermoplastic elastomer

Features:

- Writing surface on front and back.
- Has angled feet for grouping with other Nexus partitions, easels and/or IdeaWalls
- Includes 1 eraser and 4 assorted color dry erase markers.
- Designed to accommodate 4 Nexus Tablets - hung from the side posts.
- Guaranteed for 10 years

Notes:

- Some assembly required
- Related Products: Nexus X-Pegs, Nexus Caddy, Nexus Tablet, Nexus Easel, and Nexus IdeaWall

IdeaWall

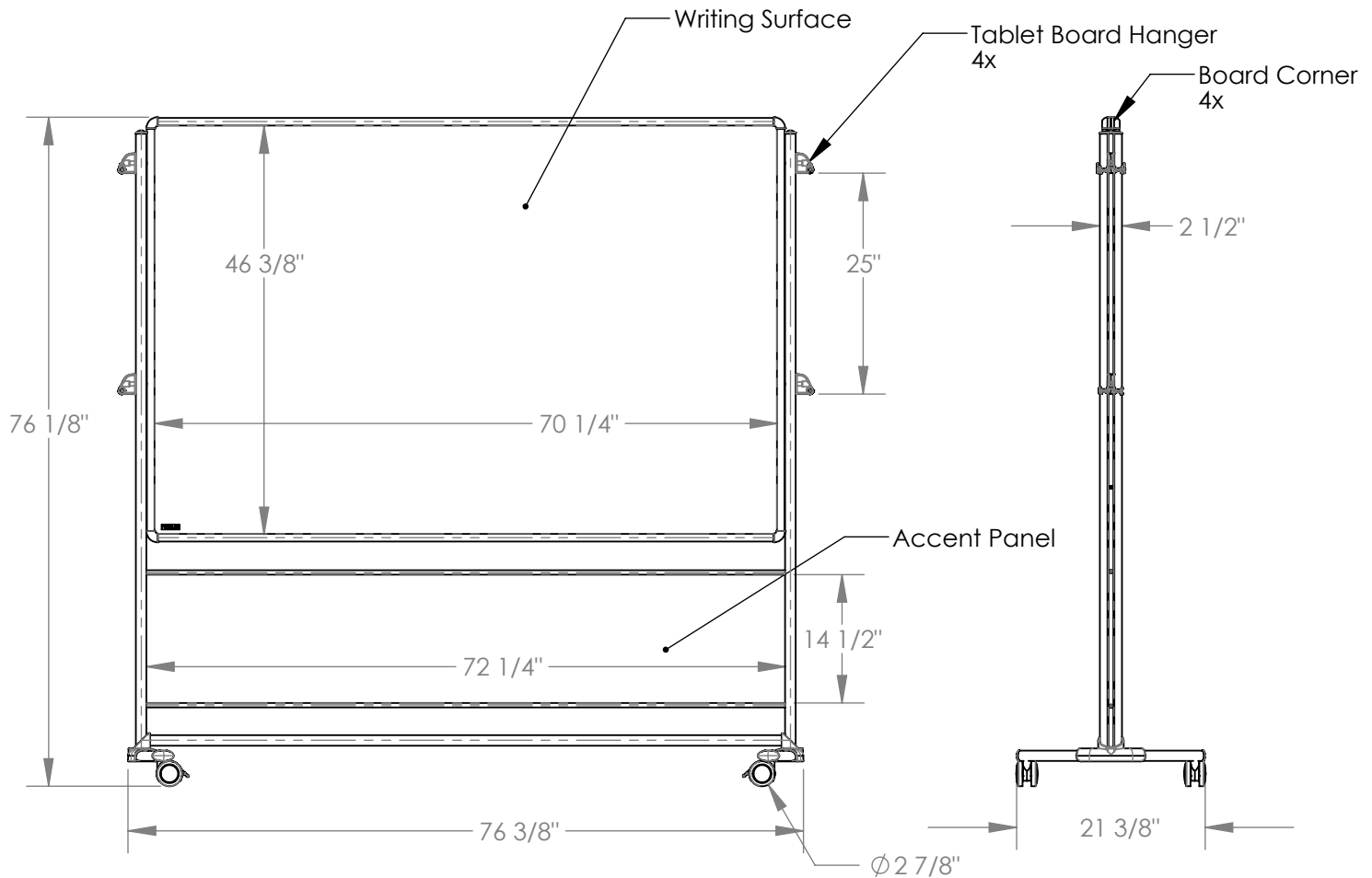

Materials:

- Framing: Satin anodized aluminum extrusion
- Foot Castings: Powder coated die cast aluminum
- Writing Surfaces: White porcelain coated 28 gauge steel sheet
- Board Corners, Rail Caps, Tablet Hangers, and Hanger Pegs: Gray thermoplastic
- Swivel Casters with Wheel Locks: Thermoplastic elastomer
- Magnetic Marker/Eraser Bin: Silver painted steel mesh weldment
- Accent Panels: Plastic

Features:

- Writing surface on the front and back.
- Has angled feet for grouping with other Nexus easels and/or IdeaWalls
- Includes 1 eraser and 4 assorted color dry erase markers.
- Designed to accommodate 4 Nexus Tablets - hung from the the side posts.
- Guaranteed 10 years

Notes:

- Some assembly required
- Related Products: Nexus X-Pegs, Nexus Caddy, Nexus Tablet, Nexus Easel and Nexus Easel Plus

Easel

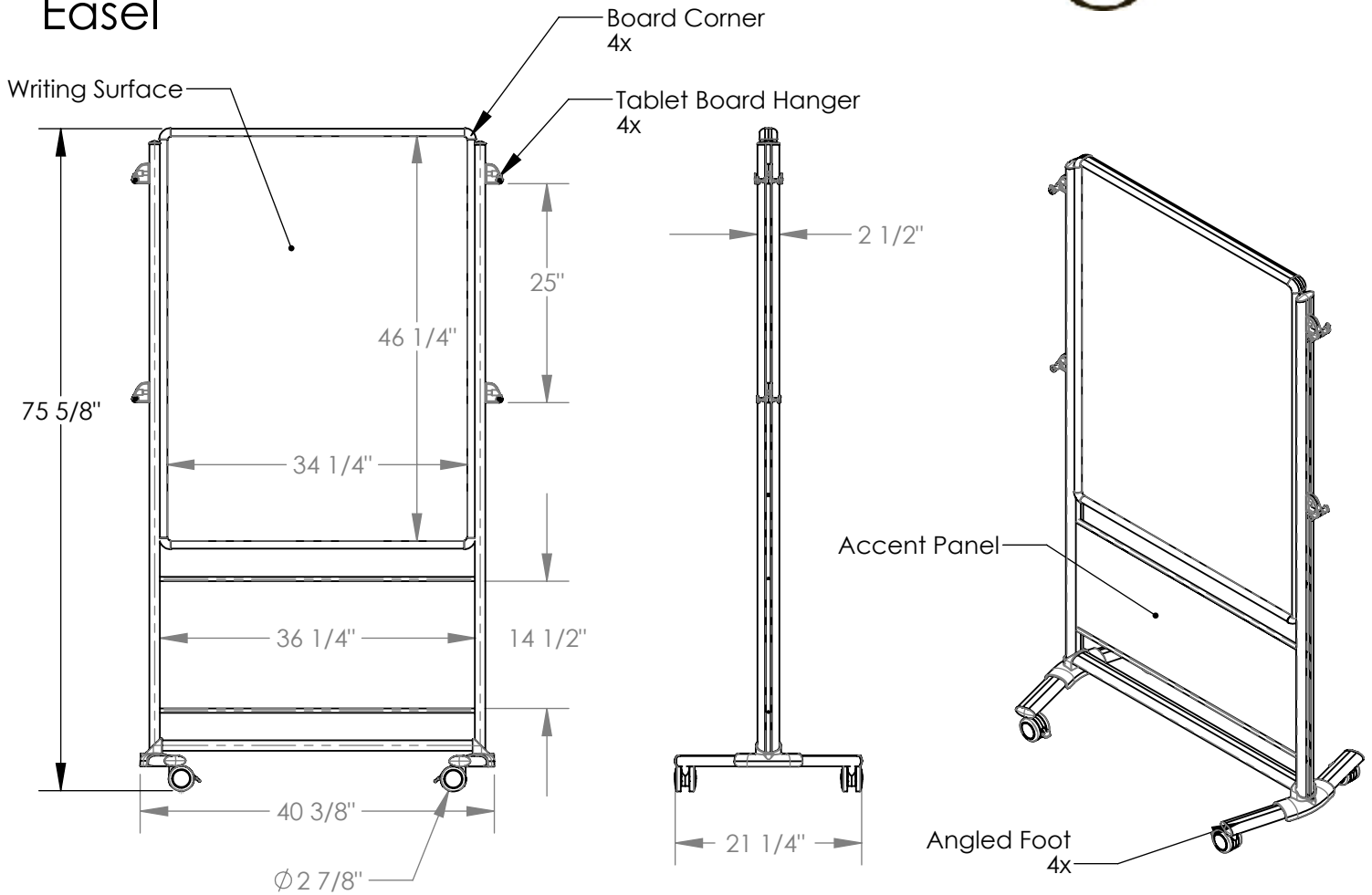

Materials:

- Framing: Satin anodized aluminum extrusion
- Foot Castings: Powder coated die cast aluminum
- Writing Surfaces: White porcelain coated 28 gauge steel sheet
- Board Corners, Rail Caps, Tablet Hangers, and Hanger Pegs: Gray thermoplastic
- Swivel Casters with Wheel Locks: Thermoplastic elastomer
- Magnetic Marker/Eraser Bin: Silver painted steel mesh weldment
- Accent Panels: Plastic

Features:

- Writing surface on front and back.
- Has angled feet for grouping with other Nexus easels and/or IdeaWalls
- Includes 1 eraser and 4 assorted color dry erase markers.
- Designed to accommodate 4 Nexus Tablets - hung from the side posts.
- Guaranteed for 10 years

Notes:

- Some assembly required
- Related Products: Nexus X-Pegs, Nexus X-Hangers, Nexus Caddy, Nexus Tablet, Nexus IdeaWall, and Nexus Easel Plus

Tablet

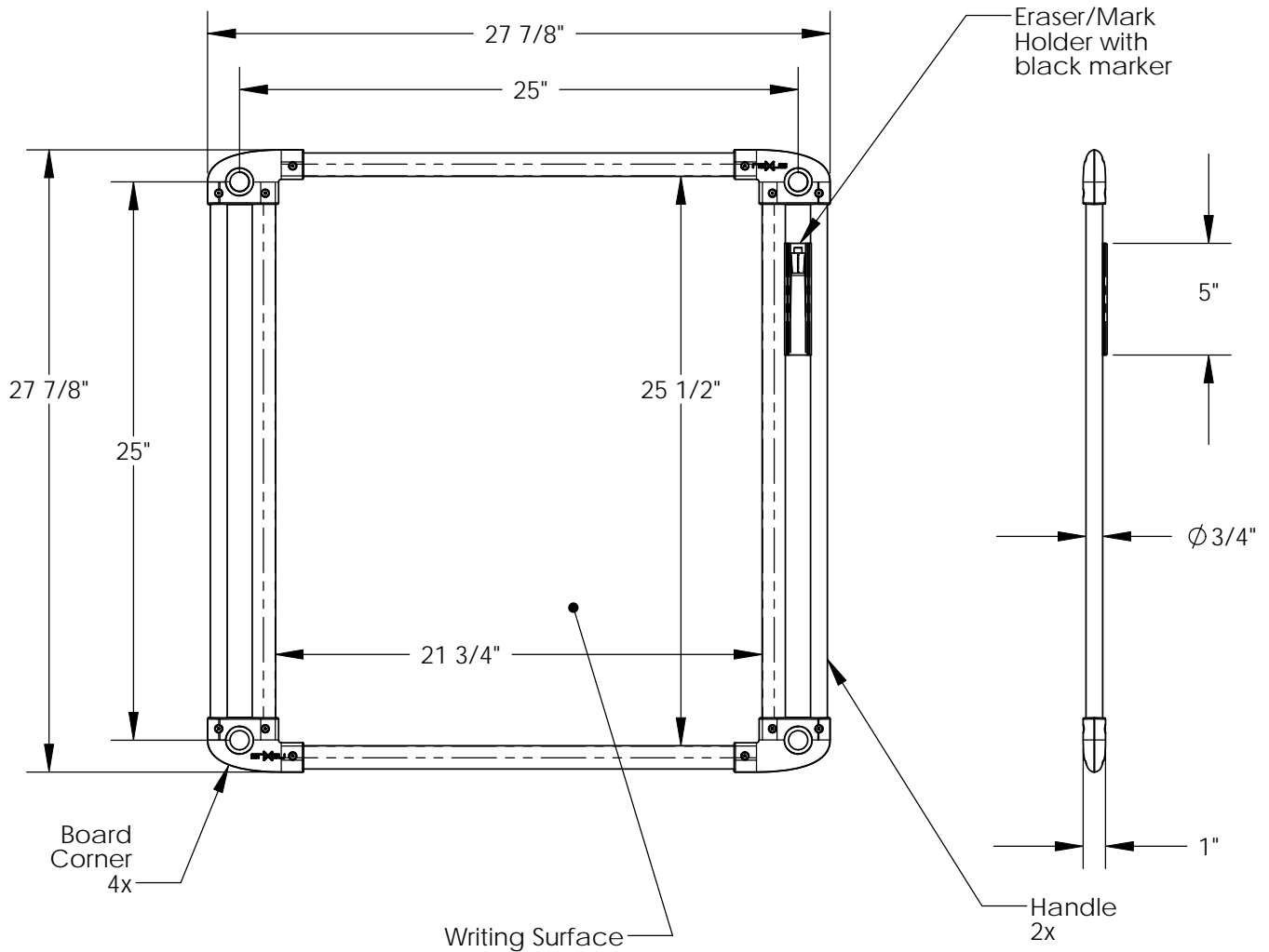

Materials:

- Framing and Handles: Satin anodized aluminum extrusion.
- Writing Surfaces: High Pressure Laminated White Dry Erase Marker Board (Non-magnetic)
- Board Corners and Eraser/Marker Holder: Gray thermoplastic

Features:

- Writing surface on front and back.
- Can be mounted on Nexus X-Pegs, Easels, and IdeaWalls in either a portrait or landscape orientation.
- Includes 1 black dry erase marker and 1 eraser/marker holder.
- The marker snaps into the eraser/marker holder, which in turn snaps into the tablet between the handle and the board frame.
- Weighs 4 1/12 lbs
- Guaranteed for 1 year

Notes:

- Related Products: Nexus X-Pegs, Nexus Caddy, Nexus Easel, and Nexus IdeaWall

Wall Mounted Marker Boards

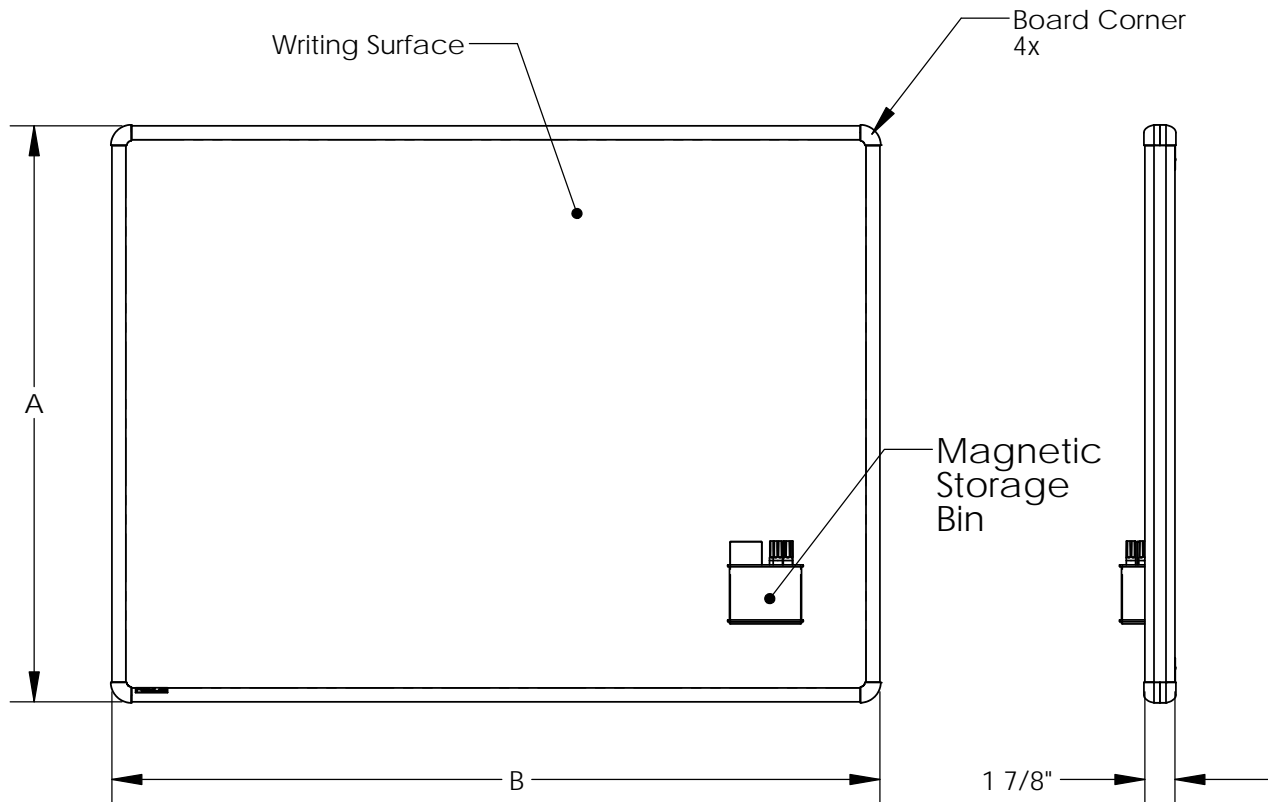

ITEM NUMBER	A	B
NEX134WMB	36"	48"
NEX146WMB	48"	72"

Materials:

- Framing: Satin anodized aluminum extrusion
- Writing Surfaces: White porcelain coated 28 gage steel sheet laminated to 1/2" thick fiber board with a mylar film backing.
- Board Corners: Gray thermoplastic
- Board Hangers (not shown): Galvanized steel stampings
- Storage Bin: Steel wire form and screen construction - Painted silver

Features:

- Board hangers are included.
- Includes 1 eraser, 4 assorted color dry erase markers, and a magnetic storage bin.
- The board is guaranteed for 10 years.