

# Flyte Mobile Frameless Whiteboard / FLYM

## Product Specifications

Questions? Give us a call! 800-543-0550

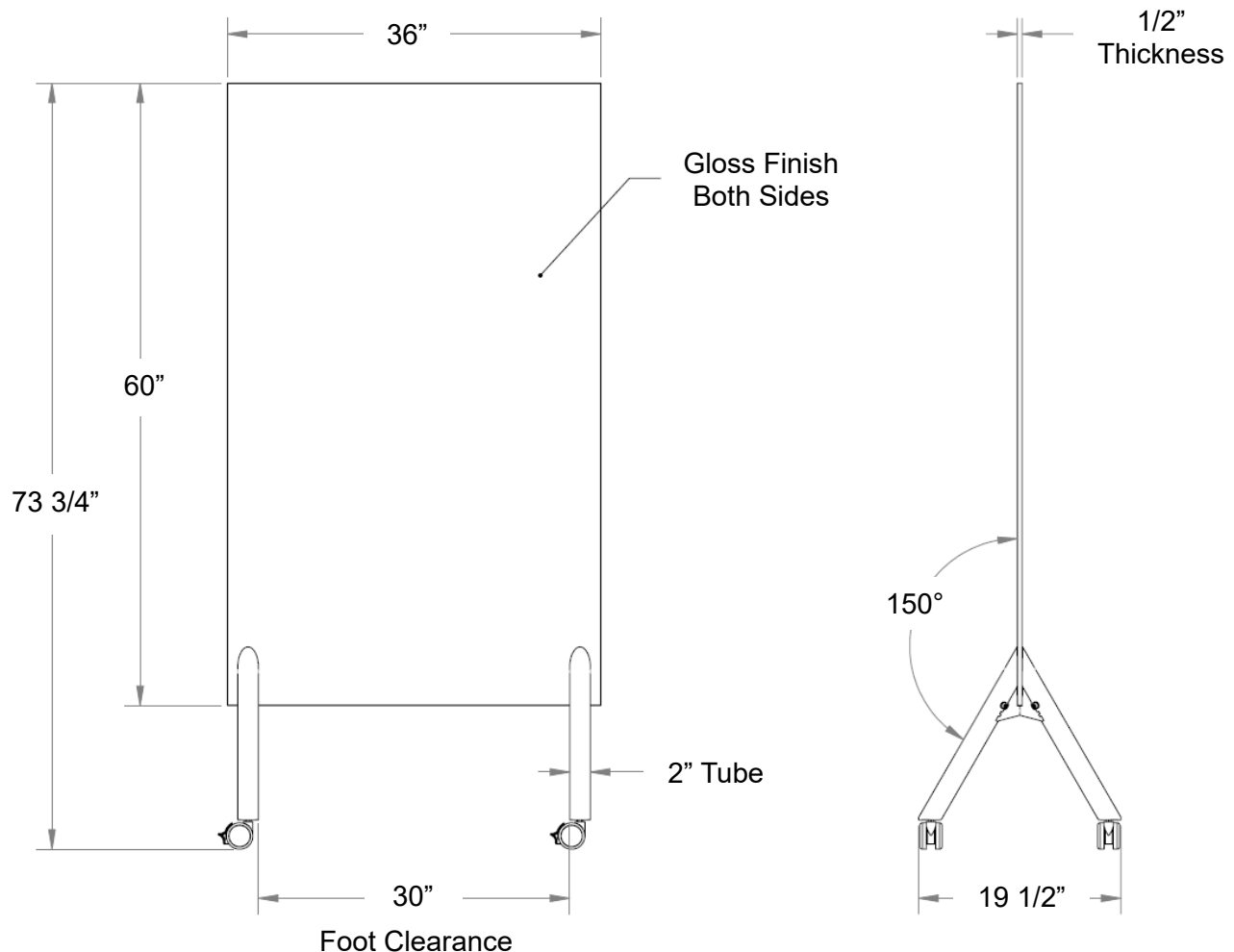

### Materials:

- Board Surface: UV coated magnetic dry erase whiteboard. Double-sided gloss finish.
- Magnetic steel skin.
- Core Material: 1/2" lightweight aluminum honeycomb.
- Dry erasable gloss edgebanding.
- Caster Legs: Powder coated steel.

### Features:

- Proprietary GUV dry erase surface.
- Lightweight all metal core construction.
- Double-sided gloss dry erase surface.
- Includes four magnetic markers and a microfiber cloth.
- Metal components are recyclable at mixed metals facility.
- Board is guaranteed for 10 years.

### Notes:

- Indoor use only.
- Some assembly required.